



## Product datasheet

---

### Captair 483 Smart

Ductless filtering fume hoods

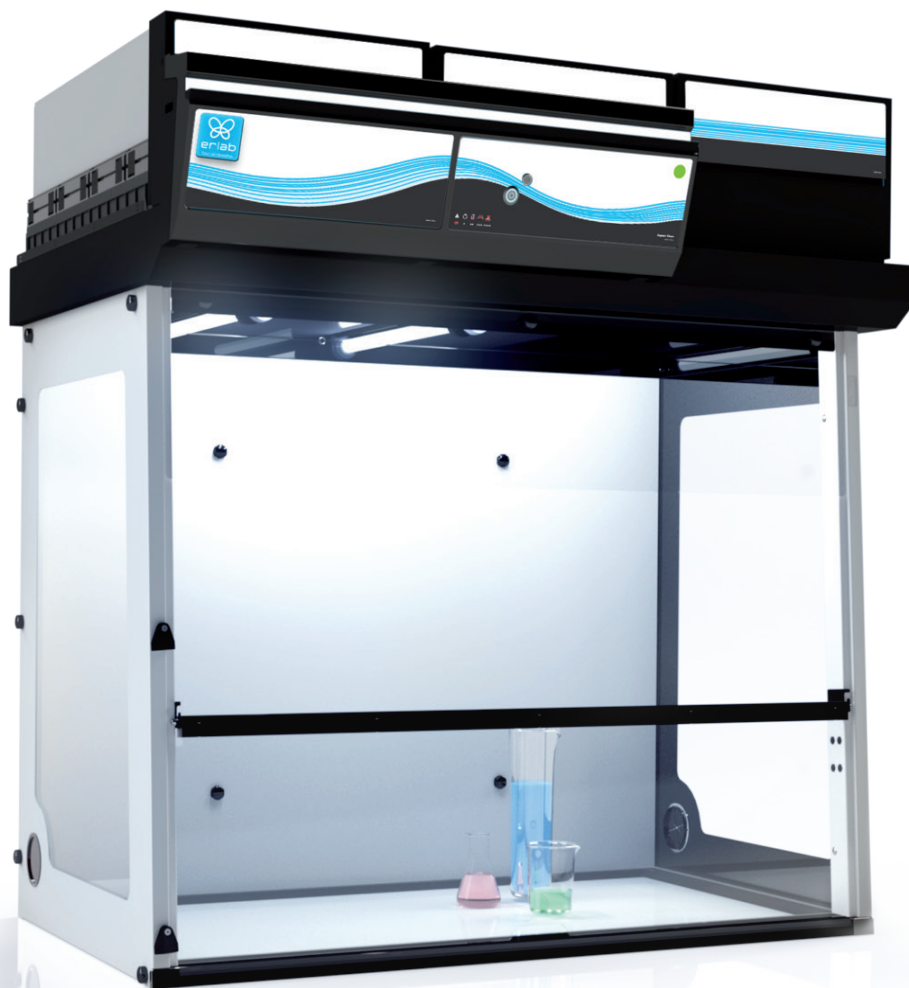

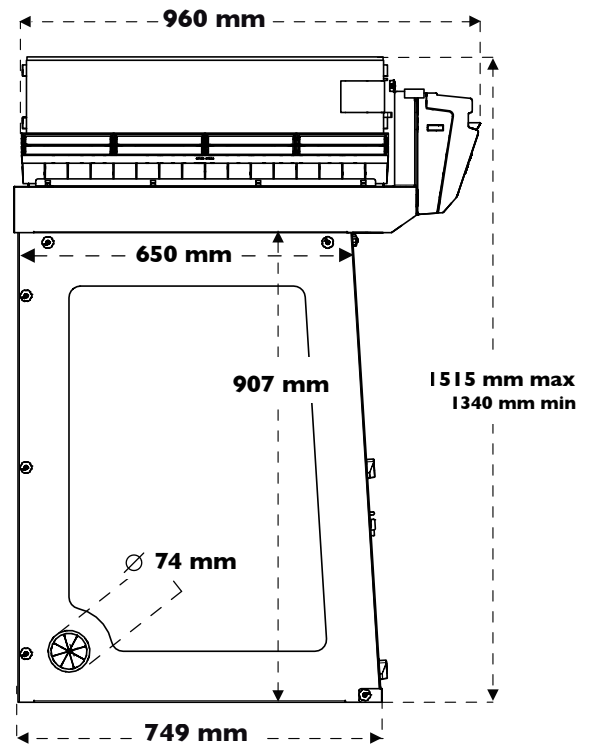
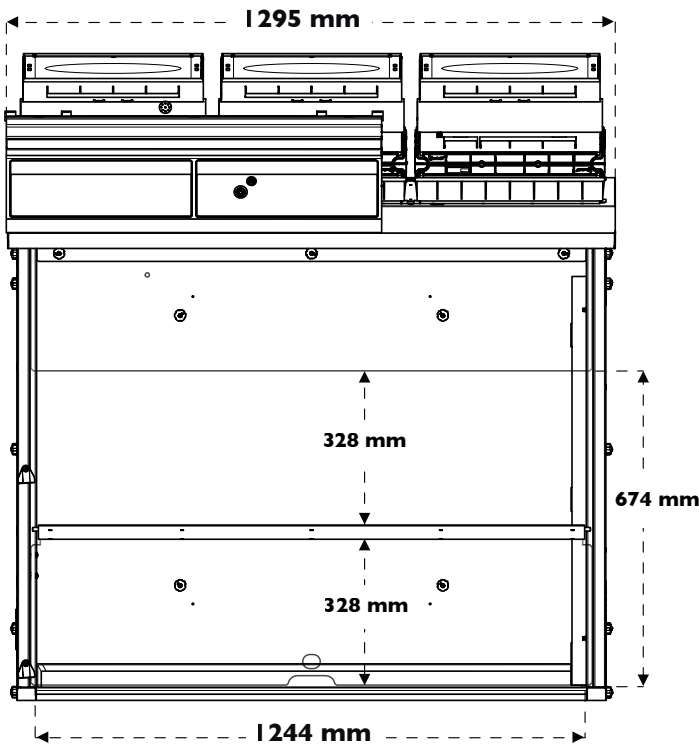

Heights according to the filtration column configuration		
Type 1C or 1P	1340 mm	Please add 150mm between the last filter and the ceiling to allow a good air recirculation and to replace filters easily
Type 2C or 1P1C or 1C1P	1435 mm	
Type 1P2C or 1P1C1P	1515 mm	

**Work surfaces with built in spill tray**

**Tempered glass**  
 Retention volume (8L)

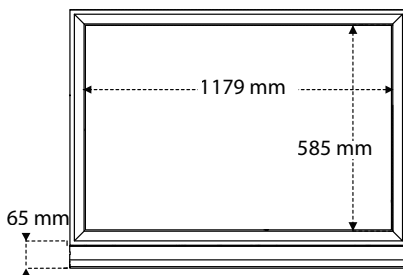

**Trespa® Top Lab<sup>PLUS</sup>**  
 Retention volume (7L)

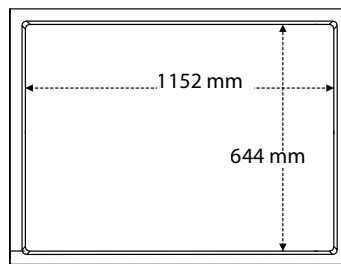

**304 L stainless steel**  
 Retention volume (18L)

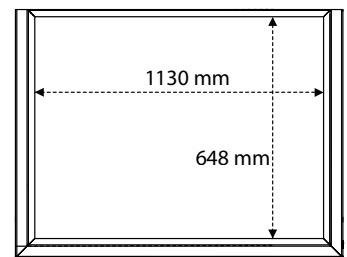

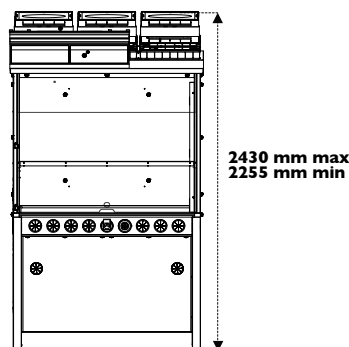

**Benchcap: fixed work bench**



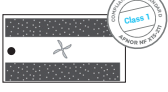

Modular design of the filtration column allows to adapt to every protection needs

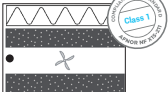
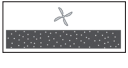
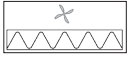
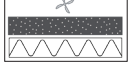
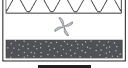
		Products handled / Applications			
		Liquid chemicals handlings	Powders handlings	Liquid chemicals and powders handlings	Liquid chemicals handlings in clean room
Customized filtration column	Class 1 according to the NF X 15-211	 2C	NA	 1P2C	 2C1P
	Class 2 according to the NF X 15-211	 1C	 1P	 1P1C	 1C1P



**Carbon filtration for gases and vapours**  
AS: For organic vapours  
BE+: Polyvalent for acid + organic vapours  
F: For formaldehyde vapours  
K: For ammonia vapours



**Particulate filtration for powders**  
HEPA H14: 99.995 % efficiency filtration of particles over 0.1 µm in size  
ULPA U17: 99.99995 % efficiency filtration of particles over 0.1 µm in size



• **Molecode**  
Automatic alarm to detect a filtration fault



**Class 1**  
= **Maximum safety**

<b>Safety Standards</b>	AFNOR NF X 15-211:2009: France - BS 7989: England DIN 12 927:Germany - EN 1822:1998 (HEPA H14 & ULPA U17 Filters) - CE Marking
<b>Air Flow</b>	660 m3/h - 135 CFM
<b>Air Face Velocity</b>	0.4 to 0.6 m/s - 79 fpm to 118 fpm
<b>Voltage/Frequency</b>	110-230 V / 50-60 Hz
<b>Power consumption</b>	160 W
<b>Sash openings</b>	Total openings or new reverso sash
<b>Structure</b>	Corrosion resistant electro-galvanized steel coated with anti-acid polymer
<b>Side and front panels</b>	Chemical resistant acrylic
<b>Filtration module</b>	Polypropylene

## Equipment

<b>Communication interface</b>	Simple communication by audible and light pulses: unit running time, air face velocity, automatic alarm to detect a filtration fault, fan failure alarm
<b>Filtration technology</b>	3 columns that can be configured to handle liquids, powders, or both
<b>Carbon filtration for gases and vapours</b>	Following filtration column configuration (see table above)
<b>Particulate filtration for powders</b>	Following filtration column configuration (see table above)
<b>eGuard</b>	APP for remote control to monitor the hood, change the settings, and deliver safety alerts immediately to your devices (mobile, tablet and PC)
<b>Internal lighting</b>	LED lighting > 650 Lux
<b>Anemometer</b>	Air face velocity alarm
<b>Anemometer</b>	Air face velocity indicator
<b>Chemical Listing</b>	List of approved chemicals
<b>Ceiling lighting</b>	Optional ceiling light button

## Accessories

<b>Work Surfaces</b>	Tempered glass / Trespa® Top LabPLUS / 304 L stainless steel
<b>Molecode</b>	Detection sensor for : Type S, for solvents / Type A, for acids / Type F, for formaldehydes
<b>Benches</b>	Fixed (Benchcap)
<b>Bench equipment</b>	Technical gases outlets, water outlets, front control valves, sink, power sockets (Only compatible with Trespa® Top Lab plus worktop and fixed bench)
<b>Particulate Pre-filter</b>	Protects the main filter(s) from dust
<b>Transparent Back Panel</b>	Clear acrylic panel for easy viewing



The Erlab Research and Development laboratory

# About Erlab

Since 1968, **Erlab** has been a specialist, inventor and world leader in **ductless, zero-emission filtering fume hoods for laboratories** to provide total safety in chemical handling.

## 1 Erlab filtration

We provide technologies to protect laboratory staff from inhaling chemicals. This is made possible thanks to our **Research and Development (R&D) department**, which has continuously improved our filtration technology **for more than 50 years**. That's why, in 2009, we invented the **ERLAB ABOVE** label for tried and tested filtration technology.

## 2 The AFNOR NF X 15-211: 2009 standard

Erlab's filtration technology conforms to the **NF X 15-211: 2009 standard**, the industry's most demanding standard for molecular filtration, developed by a committee of independent scientists and specialized manufacturers.

**This text imposes performance criteria linked to:**

- Filtration efficiency
- Containment efficiency
- Air face velocity
- Documentation: **chemical listing**

## 3 The ESP programme

A set of three services included with the purchase of each device designed to ensure your safety.



**eValiQuest** Risk analysis – Determination of protection needs – Determination of ergonomic needs.



**ValiPass** Certified installation – Total safety for handling.



**ValiGuard** Ongoing monitoring – Preventative and maintenance inspections – Device reconfiguration based on protection needs – Development of handling.

## 4 Flex technology

The combination of molecular and particulate filtration technologies allows a single device to meet laboratories' protection needs. This innovation from Erlab's R&D department offers unprecedented **flexibility, versatility and value**. A single device can be reconfigured over time and easily reassigned to other applications.

## 5 Smart technology

Smart technology is a **simple and innovative** means of communication that improves safety. This technology uses a light and sound signal to indicate the user's level of protection. The advantages of the technology are:

**1/ Light pulsation:** Real-time communication via LED light pulses intuitively alerts the user to the device's operating status.

**2/ Simplicity:** One-touch activation.

**3/ Detection system:** The exclusive detection system continuously monitors filtration performance.

**4/ Built-in monitoring:** This service provides direct access to the **status, settings and history** of your device.

France  
+33 (0) 2 32 09 55 80 | ventes@erlab.net

United States  
+1 800-964-4434 | captairsales@erlab.com

China  
+86 (0) 512 5781 4085 | sales.china@erlab.com.cn

Spain  
+34 936 732 474 | export.south@erlab.net

Germany  
0800 330 47 31 | export.north@erlab.net

United Kingdom  
+44 (0) 1722 341 940 | export.north@erlab.net

Italy  
+39 (0) 2 89 00 771 | export.south@erlab.net